



10G SFP+ ER (ER-1310) Transceiver

Hot Pluggable, Duplex LC, 1310nm DFB, SMF 40KM, DDM

Part Number: FSPP-H7-S13-40D



Overview

FSPP-H7-S13-40D Small Form Factor Pluggable SFP+ transceivers are compliant with the current SFP+ Multi-Source Agreement (MSA) Specification. The high performance uncooled 1310nm DFB transmitter and high sensitivity PIN receiver provide superior performance for 10GBASE-LR/LW applications up to SMF 40km optical links.

Applications

- 10GBASE-LR/LW Ethernet @10.3125G
- Fiber Channel 800-SM-LC-L 8GFC @8.5G, 1200-SM-LL-L 10GFC @10.51875G
- SONET OC-192 & SDH STM-64 @9.953G
- CPRI Option #7 @9.83G, #8 @10.1376G
- OTN OTU2 @10.7G, OTU2e @11.09G, OTU2f @11.32G

Features

- Compliant with IEEE802.3ae 10GBASE-LR/LW
- Compliant with CPRI Option 7, 8
- Compliant with SFF-8431, SFF-8432 SFP+ MSA
- Support 8.5Gb/s to 11.32Gb/s Multi-Rate
- Hot Pluggable
- 1310nm DFB laser transmitter
- Duplex LC connector
- 2-wire interface for management and diagnostic monitor compliant with SFF-8472
- Single +3.3V power supply
- Link distance 40km over SM fiber
- RoHS Compliant

Laser Safety

- This is a Class 1 Laser Product complies with 21 CFR 1040.10 and 1040.11 except for conformance with IEC 60825-1 Ed. 3., as described in Laser Notice No. 56, dated May 8, 2019.
- Caution: Use of control or adjustments or performance of procedure other than those specified herein may result in hazardous radiation exposure.



Absolute Maximum Ratings

Parameters	Symbol	Min.	Max.	Unit
Storage Temperature	T _{ST}	-40	+85	°C
Storage Relative Humidity	RH	5	95	%
Supply Voltage	V _{CC}	-0.5	+4.0	V

Recommended Operating Conditions

Parameters	Symbol	Min.	Typ.	Max.	Unit
Case Operating Temp. (FSPP-H7-S13-40D)	T _{OP}	0	-	+70	°C
Case Operating Temp. (FSPP-H7-S13-40Di)	T _{OP}	-40	-	+85	°C
Supply Voltage	V _{CC}	+3.13	+3.3	+3.47	V
Supply Current (FSPP-H7-S13-40D)	I _{CC}			350	mA
Supply Current (FSPP-H7-S13-40Di)	I _{CC}			380	mA

Transmitter Electro-optical Characteristics

V_{CC} = 3.13V to 3.47V, T_{OP} = 0 °C to 70 °C(FSPP-H7-S13-40D); T_{OP} = -40 °C to 85 °C(FSPP-H7-S13-40Di)

Parameters	Symbol	Min.	Typ.	Max.	Unit	Note
Operating Data Rate	DR	8.5	10.3125	11.32	Gb/s	
Optical Launch Power	P _o	0		+4	dBm	1
Optical Center Wavelength	λ _c	1260	1310	1355	nm	
Spectral Width (-20dB)	Δλ			1	nm	
Side Mode Suppression Ratio	SMSR	30			dB	
Optical Extinction Ratio	ER	3.5			dB	
Optical Eye Mask		IEEE802.3ae				
Relative Intensity Noise	RIN			-128	dB/Hz	
Differential Data Input Swing	V _{IN}	180		850	mV	
Tx Disable Input Voltage-Low (Tx ON)	TDISV _L	GND		0.8	V	
Tx Disable Input Voltage-High (Tx OFF)	TDISV _H	2.0		V _{CC}	V	
Tx Fault Output Voltage-Low (Tx Normal)	TFLTV _L	GND		0.8	V	
Tx Fault Output Voltage-High (Tx Fault)	TFLTV _H	2.0		V _{CC}	V	

Note1: The optical power is launched into a 9/125μm single mode fiber.



Receiver Electro-optical Characteristics

V_{CC} = 3.13V to 3.47V, T_{OP} = 0 °C to 70 °C(FSPP-H7-S13-40D); T_{OP} = -40 °C to 85 °C(FSPP-H7-S13-40Di)

Parameters	Symbol	Min.	Typ.	Max.	Unit	Note
Operating Data Rate	DR	8.5	10.3125	11.32	Gb/s	
Receiver Sensitivity	SEN			-16	dBm	1
Maximum Receive Power	PRX_MAX	+0.5			dBm	1
Optical Center Wavelength	λ _c	1260		1620	nm	
LOS De-Assert	LOS _D			-17	dBm	
LOS Assert	LOS _A	-30			dBm	
LOS Hysteresis	LOS _{HY}	0.5			dB	
Differential Data Output Swing	V _{OUT}	300		900	mV	
Receiver LOS Signal Output Voltage-Low	LOS _{VL}	GND		0.8	V	
Receiver LOS Signal Output Voltage-High	LOS _{VH}	2.0		V _{CC}	V	

Note1: Measured with a PRBS 2³¹-1 test pattern @10.3125Gbps BER<10⁻¹².

Pin Assignment

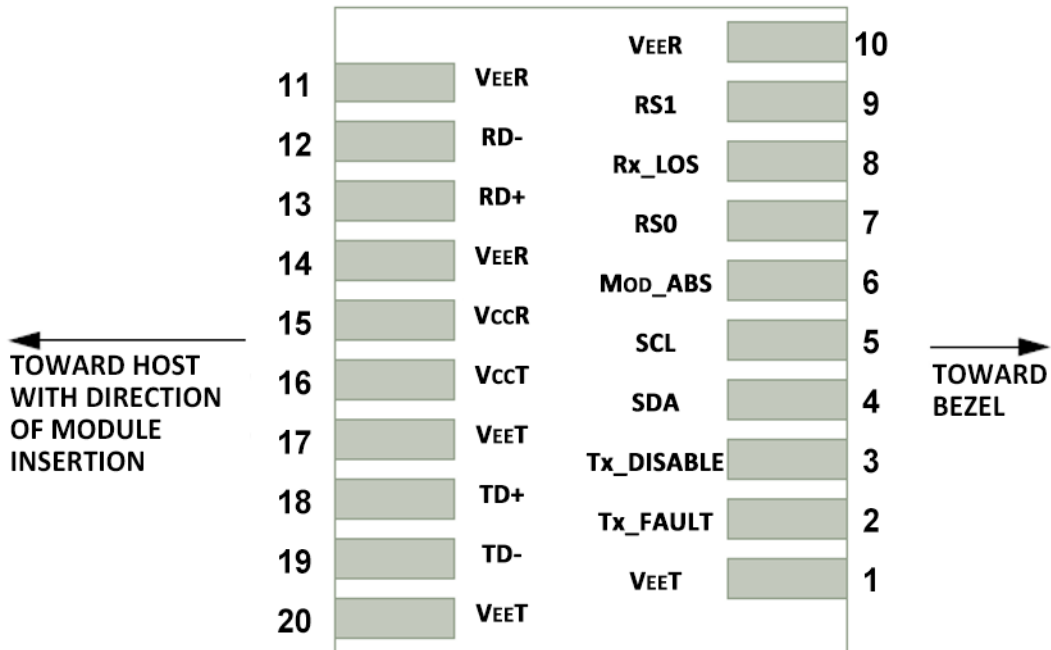

Host PCB SFP+ Pad Assignment Top View



Pin Description

Pin	Name	Function / Description
1	VEET	Transmitter Ground
2	Tx_FAULT	Transmitter Fault Indication (1)
3	Tx_DISABLE	Transmitter Disable – Turns off transmitter laser output (2)
4	SDA	2-wire Serial Interface Data Line (SDA: Serial Data Signal) (3)
5	SCL	2-wire Serial Interface Clock (SCL: Serial Clock Signal) (3)
6	MOD_ABS	Module Absent, connected to VEET or VEER in the module (3)
7	RS0	Rate Select 0, optional (5)
8	Rx_LOS	Receiver Loss of Signal Indication (4)
9	RS1	Rate Select 1, optional (5)
10	VEER	Receiver Ground
11	VEER	Receiver Ground
12	RD-	Receiver Inverted Data output, AC coupled
13	RD+	Receiver Non-Inverted Data output, AC coupled
14	VEER	Receiver Ground
15	VccR	Receiver 3.3V Power Supply
16	VccT	Transmitter 3.3V Power Supply
17	VEET	Transmitter Ground
18	TD+	Transmitter Non-Inverted Data Input, AC coupled
19	TD-	Transmitter Inverted Data Input, AC coupled
20	VEET	Transmitter Ground

Note1: Tx Fault is open collector/drain output which should be pulled up externally with a 4.7K~10KΩ resistor on the host board to supply $<V_{ccT}+0.3V$ or $V_{ccR}+0.3V$. When high, this output indicates a laser fault of some kind. Low indicates normal operation. In the low state, the output will be pulled to $<0.8V$.

Note2: Tx Disable input is used to shut down the laser output per the state table below. It is pulled up within the module with a 4.7K~10KΩ resistor. 1) Low(0~0.8V): Transmitter on; 2) Between(0.8V and 2V): Undefined; 3) High (2.0~ V_{ccT}): Transmitter Disabled; 4) Open: Transmitter Disabled.

Note3: These are the module definition pins. They should be pulled up with a 4.7K~10KΩ resistor on the host board to supply less than $V_{ccT}+0.3V$ or $V_{ccR}+0.3V$. MOD_ABS is grounded by the module to indicate that the module is present.

Note4: Rx_LOS (Loss of signal) is an open collector/drain output which should be pulled up externally with a 4.7K~10KΩ resistor on the host board to supply $<V_{ccT}+0.3V$ or $V_{ccR}+0.3V$. When high, this output indicates the received optical power is below the worst case receiver sensitivity (as defined by the standard in use). Low indicates normal operation. In the low state, the output will be pulled to $<0.8V$.

Note5: Tied to ground through a 30K ohm resistor.



Digital Diagnostic Functions

As defined by the SFP MSA (SFF-8472) Ficer's SFP+ transceivers provide digital diagnostic functions via a 2-wire serial interface, which allows real-time access to the following operating parameters:

- Transceiver temperature
- Laser bias current
- Transmitted optical power
- Received optical power
- Transceiver supply voltage

It also provides a sophisticated system of alarm and warning flags, which may be used to alert end-users when particular operating parameters are outside of a factory-set normal range.

The operating and diagnostics information is monitored and reported by a Digital Diagnostics Controller (DDC) inside the transceiver, which is accessed through the 2-wire serial interface. When the serial protocol is activated, the serial clock signal (SCL pin) is generated by the host. The positive edge clocks data into the SFP+ transceiver into those segments of its memory map that are not write-protected. The negative edge clocks data from the SFP+ transceiver. The serial data signal (SDA pin) is bi-directional for serial data transfer. The host uses SDA in conjunction with SCL to mark the start and end of serial protocol activation. The memories are organized as a series of 8-bit data words that can be addressed individually or sequentially.

For more detailed information including memory map definitions, please see the SFP MSA (SFF-8472) Specification.



Digital Diagnostic Memory Map

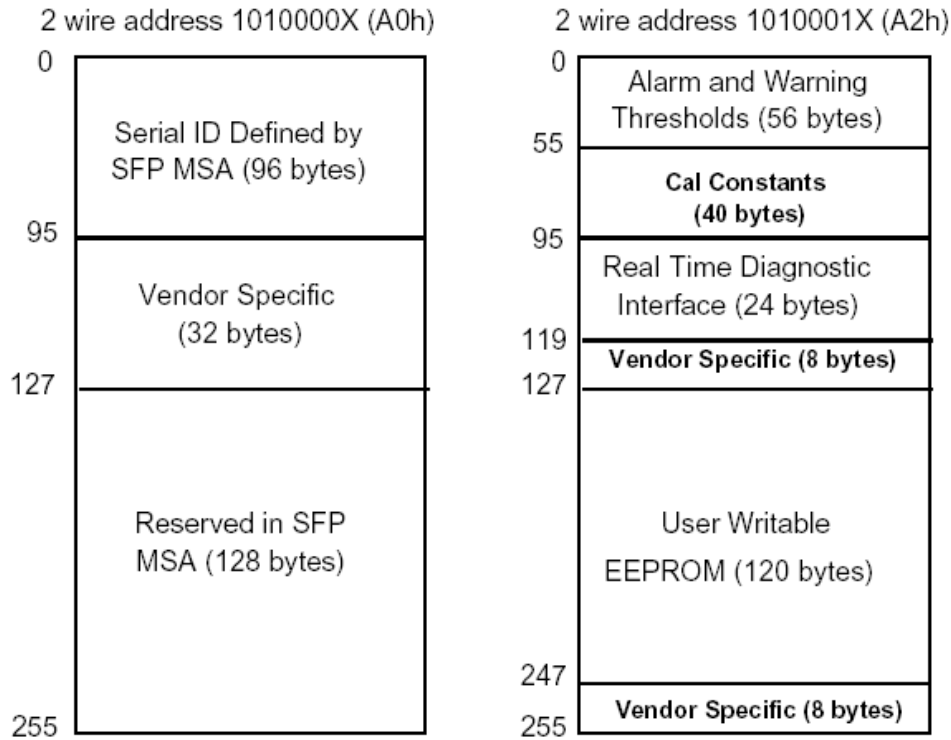

Digital Diagnostic Monitoring Characteristics

Parameter	Accuracy	Unit	Note
Temperature	±3	°C	Internal Calibration
Supply Voltage	±0.1	V	Internal Calibration
Tx Bias Current	±5	mA	Internal Calibration
Tx Output Power	±3	dB	Internal Calibration
Rx Received Optical Power	±3	dB	Internal Calibration



Mechanical Dimensions

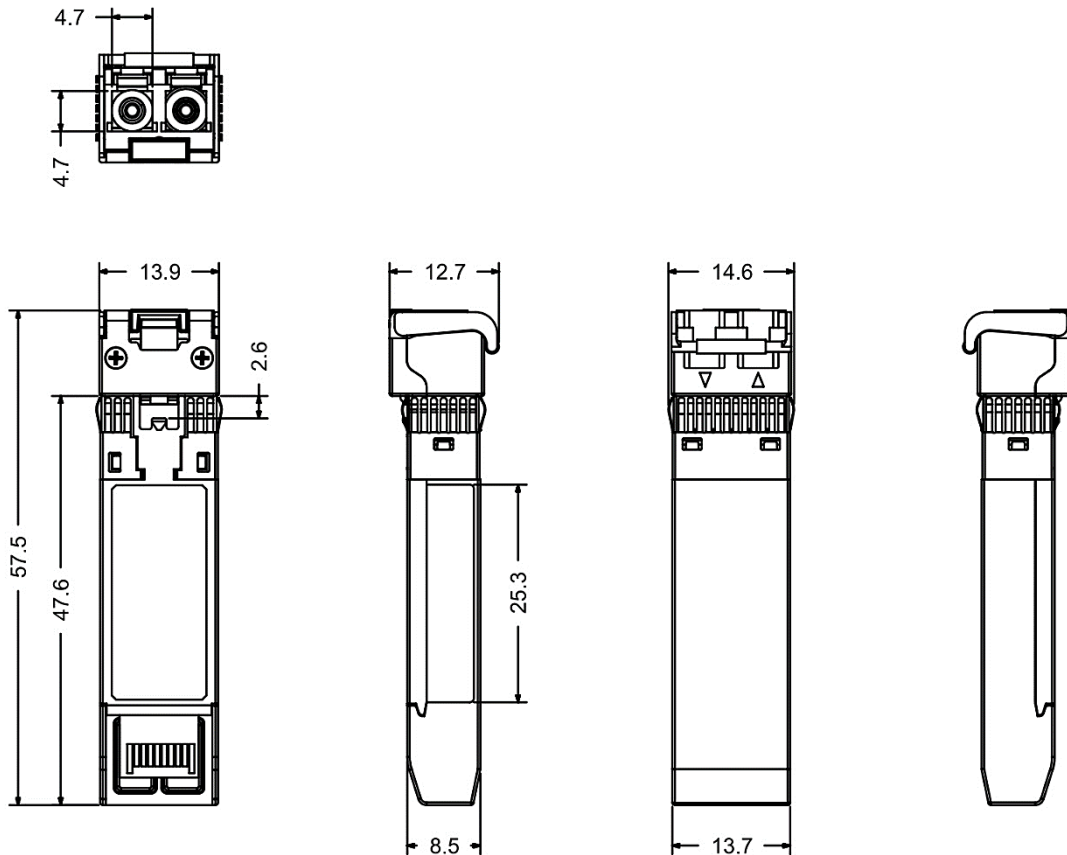

(All Dimensions are $\pm 0.20\text{mm}$ Unless Otherwise Specified, Unit: mm)

Ordering Information

Part No.	Tx	Rx	Link	DDM	Temp.
FSP-PH7-S13-40D	1310nm	1260nm	SMF 40km	Yes	0~70°C
FSP-PH7-S13-40Di		~ 1620nm			-40~85°C

Note: Distances are indicative only. To calculate a more precise link budget based on specific conditions in your application, please refer to the optical characteristics.